

INSTALLATION AND MAINTENANCE INSTRUCTIONS

SpectrAlert Strobe and Horn/Strobe

For use with the following 24-volt models:

Strobes: S2475RLP, S2475ALP, S2475GLP, S2475BLP

Horn/Strobes: P2475RLP, P2475ALP, P2475GLP, P2475BLP

Lens colors: "RLP" for Red, "ALP" for Amber, "GLP" for Green, "BLP" for Blue

The "P" suffix indicates no markings on the housing; add suffix "W" for white housing models.

The Products to which this manual applies may be covered by one or more of the following

U.S. Patent numbers: 5,914,665; 5,850,178; 5,593,569; 5,598,139; 6,049,446; 6,133,843



3825 Ohio Avenue, St. Charles, Illinois 60174

1-800-SENSOR2, FAX: 630-377-6495

www.systemsensor.com

SPECTRAlert

Specifications

Voltage Range: DC or Full-Wave Rectified

Strobes and Horn/Strobes: 24-volt models – 20 to 30 volts

(with MDL module): 24-volt models – 21 to 30 volts

NOTE: Combo unit will operate on walk tests with on-time durations of 1 sec. or greater.

Flash Rate: 1 Flash Per Second

Operating Temperature: 32° F to 120° F (0° C to 49° C)

Light Output: 75 candela

Sound Output: Sound output levels are established at Underwriters Laboratories in their reverberant room. Always use the sound output specified as UL Reverberant Room when comparing products.

Listings: UL S4011 (Horn/Strobe), UL S3593 (Strobe)

General Description

The SpectrAlert series notification appliances are designed to meet the requirements of NFPA, The National Fire Alarm Code, and UL. Also, check with your local Authority Having Jurisdiction for other codes or standards that may apply.

This SpectrAlert S2475XXX Series Strobe and P2475XXX Series style Horn/Strobe can be installed in systems using 24-volt panels having DC or full-wave rectified (FWR) power supplies. The models can also be installed in systems requiring synchronization (module MDL required) or systems that do not require synchronization (no module required).

NOTICE: This manual shall be left with the owner/user of this equipment.

Fire Alarm System Considerations

Temporal and Non-Temporal Coded Signals:

The American National Standards Institute and the National Fire Alarm Code require that all horns used for building evacuation installed after July 1, 1996, must produce Temporal Coded Signals.

Signals other than those used for evacuation purposes do not have to produce the Temporal Coded Signal. Temporal coding is accomplished by interrupting a steady sound in the following manner:

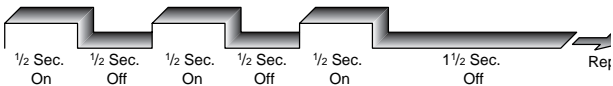

Power Supply Considerations

Panels typically supply DC filtered voltage or FWR (full-wave rectified) voltage. The system design engineer must calculate the number of units used in a zone based on the type of panel supply. Be certain the sum of all the device currents do not exceed the current capability of the panel. Calculations are based on using the device current found in the subsequent charts and must be the current specified for the type of panel power supply used.

Wire Sizes

The designer must be sure that the last device on the circuit has sufficient voltage to operate the device within its rated voltage. When calculating the voltage available to the last device, it is necessary to consider the voltage drop due to the resistance of the wire. The thicker the wire, the less the voltage drop. Generally, for purposes of determining the wire size necessary for the system, it is best to consider all of the devices as "lumped" on the end of the supply circuit (simulates "worst case").

Typical wire size resistance:

18 AWG solid: Approximately 8 ohms/1,000 ft.

16 AWG solid: Approximately 5 ohms/1,000 ft.

14 AWG solid: Approximately 3 ohms/1,000 ft.

12 AWG solid: Approximately 2 ohms/1,000 ft.

Example: Assume you have 10 devices on a zone and each requires 50 mA average and 2000 Ft. of 14 AWG wiring (total length = outgoing + return). The voltage at the end of the loop is 0.050 amps per device x 10 devices x 3 ohms/1,000 ft. x 2000 ft = 3 volts drop.

The same number of devices using 12 AWG wire will produce only 2 volts drop. The same devices using 18 AWG wire will produce 8 volts drop. Consult your panel manufacturer's specifications, as well as SpectrAlert's operating voltage range to determine acceptable voltage drop.

Note: If class "A" wiring is installed, the wire length may be up to 4 times the single wire length in this calculation.

Current Draws

Strobe:

| AVERAGE CURRENT (mA) | | | | | | PEAK CURRENT (mA) | | | | | | IN RUSH CURRENT (mA) | | | | | |
|----------------------|-----|-----|-----|-----|-----|-------------------|-----|-----|-----|-----|-----|----------------------|-----|-----|-----|-----|-----|
| 24V Models | | | | | | 24V Models | | | | | | 24V Models | | | | | |
| 20V | | 24V | | 30V | | 20V | | 24V | | 30V | | 20V | | 24V | | 30V | |
| DC | FWR | DC | FWR | DC | FWR | DC | FWR | DC | FWR | DC | FWR | DC | FWR | DC | FWR | DC | FWR |
| 169 | 220 | 140 | 191 | 115 | 174 | 460 | 560 | 450 | 570 | 420 | 620 | 190 | 230 | 220 | 290 | 290 | 370 |

Horn/Strobe:

| | | | AVERAGE CURRENT (mA) | | | | | |
|--------------------|-----------------|-----------|----------------------|-----|-----|-----|-----|-----|
| | | | 24V Models | | | | | |
| Tone | High/Low Volume | Temp /Non | 20V | | 24V | | 30V | |
| | | | DC | FWR | DC | FWR | DC | FWR |
| Electro-mech. | High | Temp | 188 | 241 | 165 | 209 | 144 | 200 |
| | | Non | 186 | 238 | 163 | 211 | 145 | 202 |
| | Low | Temp | 180 | 232 | 153 | 204 | 132 | 189 |
| | | Non | 181 | 232 | 154 | 204 | 132 | 190 |
| 3000 Hz Interrupt. | High | Temp | 193 | 246 | 168 | 214 | 152 | 207 |
| | | Non | 188 | 242 | 167 | 217 | 150 | 210 |
| | Low | Temp | 183 | 234 | 157 | 206 | 136 | 193 |
| | | Non | 182 | 232 | 156 | 205 | 137 | 195 |

Sound Output Guide

UL Reverberant Room dBA@ volts DC

Anechoic dBA @10 ft./volts DC

| Temporal | Low Volume | Electromechanical | 20 | 24 | 30 | 20 | 24 | 30 |
|--------------|-------------|---------------------|----|----|----|-----|-----|-----|
| | | | 75 | 75 | 79 | 94 | 96 | 98 |
| Temporal | High Volume | Electromechanical | 82 | 82 | 82 | 100 | 101 | 102 |
| | | 3000 Hz Interrupted | 82 | 85 | 85 | 100 | 101 | 102 |
| | Low Volume | Electromechanical | 79 | 82 | 85 | 94 | 96 | 98 |
| | | 3000 Hz Interrupted | 82 | 82 | 85 | 94 | 96 | 98 |
| Non-Temporal | High Volume | Electromechanical | 85 | 88 | 88 | 100 | 101 | 102 |
| | | 3000 Hz Interrupted | 88 | 88 | 88 | 100 | 101 | 102 |
| | Low Volume | Electromechanical | 79 | 82 | 85 | 94 | 96 | 98 |
| | | 3000 Hz Interrupted | 82 | 82 | 85 | 94 | 96 | 98 |

Horn Selections

Horns are factory set for high volume, temporal code, and electromechanical tone.

Tones:

Two tones may be selected using the jumper plugs located on the printed circuit board. With the jumper offset, the tone is the Electromechanical sound. With the jumper in place, the tone is a 3 kHz sound.

Temp/Non-Temp:

Temporal coding or Non-Temporal coding can be selected using the jumper plugs located on the printed circuit board. With the jumper offset, the tone pattern is the Temporal Coded Signal. With the jumper in place, the Non-Temporal code (continuous) tone is active.

NOTE: When powered from FWR supply, the tones will be modulated (turned on and off) by 120Hz, causing the tones to sound different from DC power.

High/Low Volume:

High or low volume may be selected using the jumper plugs located on the printed circuit board. With the jumper in place, the sound output level is the high level. With the jumper offset, the sound output level is the low level. The low volume setting must NOT be used when the device is powered from a 12-volt panel.

NOTE: Always power down devices before setting jumpers.

System Operation: Non-Synchronized Devices

Figure 1A. Any combination of models powered by a 2-wire circuit:

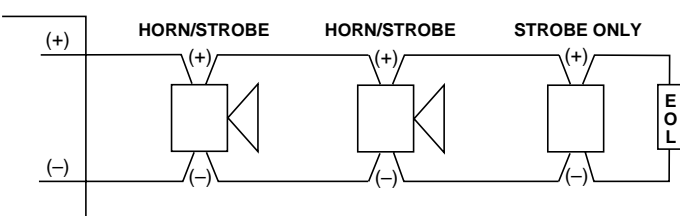

Figure 1B: Horns and strobes powered in tandem:

NOTE: Supply power must be continuous for proper operation.

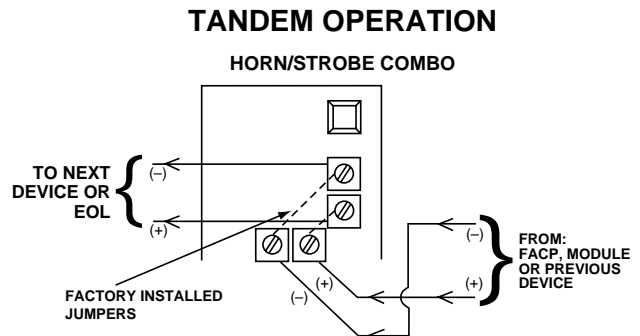

Figure 2A. Any combination of models powered by a 4-wire circuit to provide independent horn and strobe operation (Remove factory installed jumpers, see Figure 2B):

NOTE: Strobes must be powered continuously for horn operation.

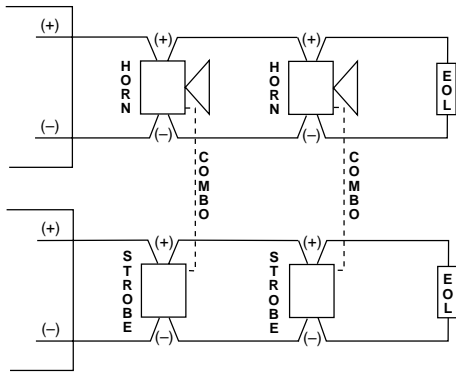

Figure 2B: Horns and strobes powered independently (Horn operated on coded power supply):

NOTE: Strobes must be powered continuously for horn operation.

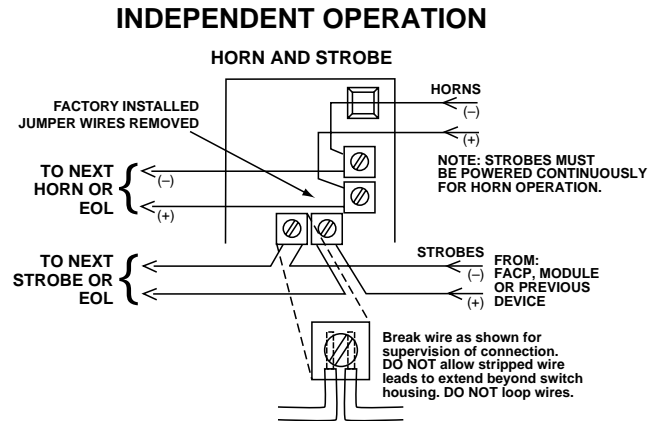
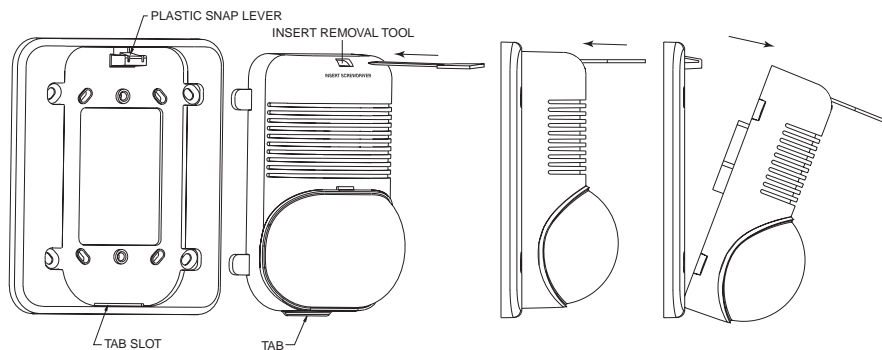

Figure 3: Removal of horns and strobes from mounting plates:

To remove units from mounting plates, insert Quick Click Removal Tool as shown to unlock snap. While pushing in Removal Tool to release the snap, pull back on the horn/strobe. Hinge the horn/strobe module, disengage the Locking Rib, and lift the horn/strobe away from the mounting plate.



Please refer to insert for the Limitations of Fire Alarm Systems



The Limitations of Horn/Strobes

The horn/strobe or strobe will not work without power. The horn/strobe gets its power from the fire/security panel monitoring the alarm system. If power is cut off for any reason, the horn/strobe will not provide the desired audio or visual warning.

The horn/strobe may not be heard. The loudness of the horn meets (or exceeds) current Underwriters Laboratories' standards. However, the horn may not alert a sound sleeper or one who has recently used drugs or has been drinking alcoholic beverages. The horn may not be heard if it is placed on a different floor from the person in hazard or if placed too far away to be heard over the ambient noise such as traffic, air conditioners, machinery or music appliances that may prevent alert persons from hearing the alarm. The horn may not be heard by persons who are hearing impaired.

NOTE: Strobes must be powered continuously for horn operation.

The signal strobe may not be seen. The electronic visual warning signal

uses an extremely reliable xenon flash tube. It flashes at least once every second. The strobe must not be installed in direct sunlight or areas of high light intensity (over 60 foot candles) where the visual flash might be disregarded or not seen. The strobe may not be seen by the visually impaired.

The signal strobe may cause seizures. Individuals who have positive photic response to visual stimuli with seizures, such as persons with epilepsy, should avoid prolonged exposure to environments in which strobe signals, including this strobe, are activated.

The signal strobe cannot operate from coded power supplies. Coded power supplies produce interrupted power. The strobe must have an uninterrupted source of power in order to operate correctly. System Sensor recommends that the horn and signal strobe always be used in combination so that the risks from any of the above limitations are minimized.

Three-Year Limited Warranty

System Sensor warrants its enclosed strobe or horn/strobe to be free from defects in materials and workmanship under normal use and service for a period of three years from date of manufacture. System Sensor makes no other express warranty for this strobe or horn/strobe. No agent, representative, dealer, or employee of the Company has the authority to increase or alter the obligations or limitations of this Warranty. The Company's obligation of this Warranty shall be limited to the repair or replacement of any part of the strobe or horn/strobe which is found to be defective in materials or workmanship under normal use and service during the three year period commencing with the date of manufacture. After phoning System Sensor's toll free number 800-SENSOR2 (736-7672) for a Return Authorization number, send defective units postage prepaid to: System

Sensor, Repair Department, RA # _____, 3825 Ohio Avenue, St. Charles, IL 60174. Please include a note describing the malfunction and suspected cause of failure. The Company shall not be obligated to repair or replace units which are found to be defective because of damage, unreasonable use, modifications, or alterations occurring after the date of manufacture. In no case shall the Company be liable for any consequential or incidental damages for breach of this or any other Warranty, expressed or implied whatsoever, even if the loss or damage is caused by the Company's negligence or fault. Some states do not allow the exclusion or limitation of incidental or consequential damages, so the above limitation or exclusion may not apply to you. This Warranty gives you specific legal rights, and you may also have other rights which vary from state to state.

Mounting Diagrams

Screw types used for mounting:

A = 8-32 x 3/4 flat head

B = 6-32 x 1 1/16 pan head

Strobe or Horn/Strobe with small footprint mounting plate:

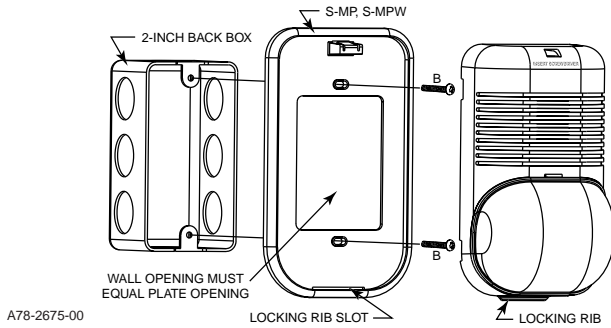

1. Mount plate to back box using screws B.
2. Break off four tabs from unit.
3. Complete field wiring, making sure wall opening is large enough for terminals to fit through.
4. Insert locking rib into slot on plate.
5. Press into plate; unit will make a “click” when it has locked into place.

Strobe or Horn/Strobe with universal mounting plate:

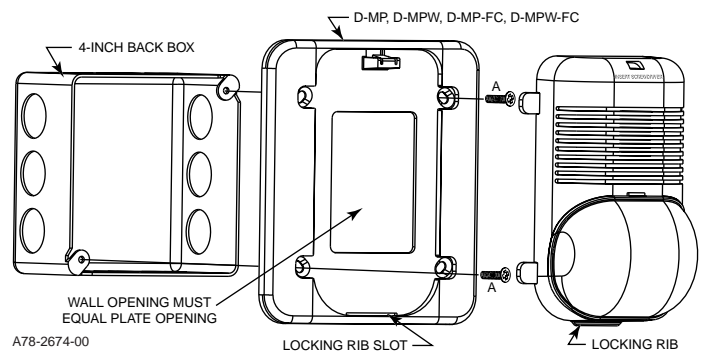

1. Mount plate to back box using screws A, making sure wall opening is equal to the plate opening.
2. Complete field wiring.
3. Insert locking rib into slot on plate.
4. Press into plate, unit will make a “click” when it has locked into place.

Strobe or Horn/Strobe surface mount:

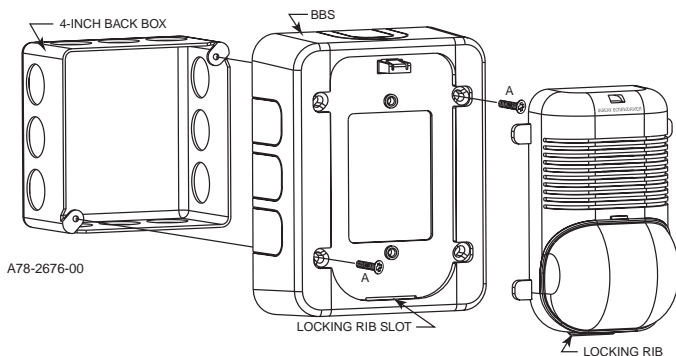

1. Mount skirt to back box with screws A.
2. Complete field wiring.
3. Insert locking rib on unit into slot on skirt.
4. Press into skirt; unit will make a “click” when it has locked into place. (Note: Strobe and skirt may also be mounted to a 2-inch box using screws B instead of screws A.)