

• Melbourne

Unit C2,
2A Westall Rd
Springvale
Vic 3171
Tel: (03) 9562 7577
Fax: (03) 9562 8044
sales.vic@pertronic.com.au

• Sydney

Unit 24
287 Victoria Rd
Rydalmere
NSW 2116
Tel.: (02) 9638 7655
Fax: (02) 9638 7688
sales.nsw@pertronic.com.au

• Brisbane

31A Cordova St
Milton
Qld 4064
Tel: (07) 3368 3878
Fax: (07) 3368 3863
sales.qld@pertronic.com.au

Electro - Magnetic Door Holders

Pertronic Industries offer a comprehensive range of Electro-Magnetic door holders which are low cost, extremely reliable, robust and aesthetically pleasing.

This quality product is designed for maximum flexibility during installation, e.g. the same door holder is floor/ceiling or wall mount; surface mount door holders have a choice of two holding force settings.

This cost-effective product range will help save you time and money on site.

Features:

- All electro-magnetic door holders are fitted with a residual magnetism release pin, for quick release
- Durable powder coat finish
- Elegant design
- Easy to install
- Very reliable and robust
- Low cost

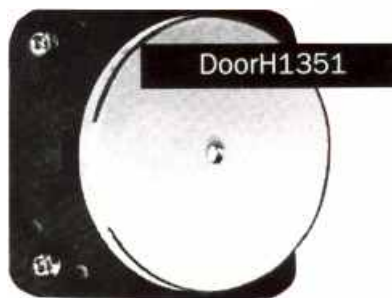

*Two holding
force settings*

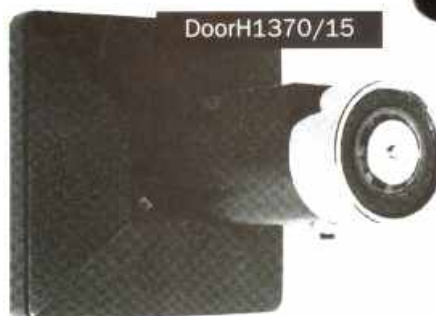
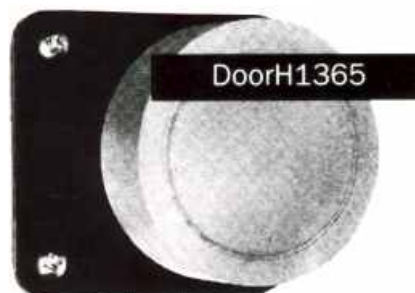

*Convertible
floor/ceiling
or wallmount*

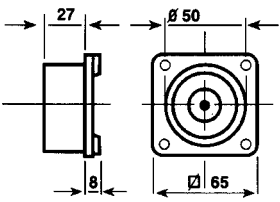
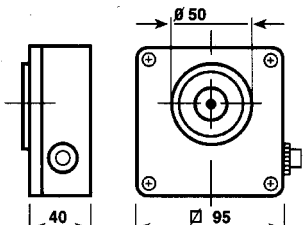
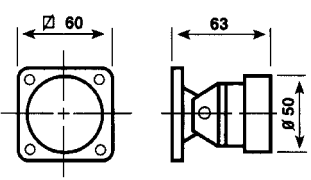

MODEL NO	DOORH1330 Electro-magnetic door holder	DOORH1350 Electro-magnetic door holder	DOORH1365 Magnetic door holder
Description	Electro-magnet designed to hold fire/smoke check doors open for convenience and release them automatically in the event of fire. Supplied with keeper plate.	Like 1330 but with facility to halve the holding force. Connections are on the printed circuit inside the housing. Release button can be placed on either side. Supplied with keeper plate.	Permanent magnet to hold open the doors and release them automatically when electro-magnet receives a voltage pulse.
			
HOUSING COLOUR	Thermoplastic base Black	Aluminium die-cast and thermoplastic Housing white - cover black	Aluminium die-cast and thermoplastic Black
POWER SUPPLY AND CURRENT	24Vdc - 60mA - 1.4W	24Vdc - 60mA - 1.4 W	24Vdc - 250mA - 6W
CONNECTIONS	Two - 0.35 x 20cm. wires	Screw terminals	Two - 0.35 x 20cm. wires
HOLDING FORCE	~ 50kg	~ 25/50 Kg	~ 25 Kg
PIECE PER PACKAGE	1	1	1
WEIGHT OF UNIT	420 gr.	700 gr.	900 gr.
ACCESSORIES SPARE PARTS AND OTHER MODELS	★ ~ 100Kg Holding force	● Adhesive fixing template for electro-magnet. ● Wall plugs and fixing screws. ★ ~ 100 Kg Holding Force	

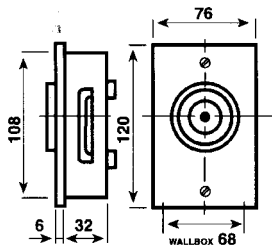
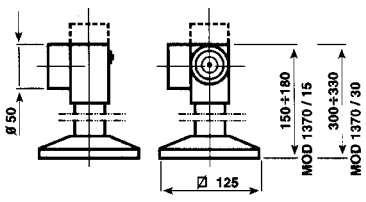
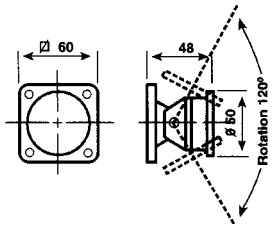
MODEL NO	DOORH1368 Flush mounting electro-magnetic door holder	DOORH1370/15 - 1370/30 Electro-magnetic door holder with bracket.	DOORH1351 Keeper Plate
Description	Flush mounting version of 1330. Front cover in anodized aluminium. Supplied with keeper plate.	The use of the bracket enables the installation on floors, ceilings and walls. The total height of 15 cm (MOD. 1370/15) or 30 cm (MOD. 1370/30) can be adjusted By 3 cm. Supplied with release button and keeper plate.	The Keeper comprises of a heavy duty thermoplastic mounting base with a spring loaded nickel plated keeper plate. The keeper plate is able to rotate by 60° from its central axis.
			
HOUSING COLOUR	Galvanized steel box Natural aluminium	Steel bracket: electro-magnetic support in aluminium Black	
POWER SUPPLY AND CURRENT	24Vdc - 60mA - 1.4W	24Vdc - 60mA - 1.4W	
CONNECTIONS	Two - 0.35 x 20cm. wires	Two - 0.35 x 20cm. wires	
HOLDING FORCE	~ 50 Kg	~ 50 Kg	
PIECE PER PACKAGE	1	1	
WEIGHT OF UNIT	650 gr.	1.200 - 1.550 gr.	
ACCESSORIES SPARE PARTS AND OTHER MODELS		● Base cover ★ ~ 100Kg Holding Force	

PERTRONIC INDUSTRIES PTY LTD

Melbourne

Unit C2, Adamco Business Park
2A Westall Rd
Springvale Vic 3171
Telephone: (03) 9562 7577
Fax: (03) 9562 8044
sales.vic@pertronic.com.au

Sydney

Unit 24
287 Victoria Rd
Rydalmere NSW 2116
Telephone: (02) 9638 7655
Fax: (02) 9638 7688
sales.nsw@pertronic.com.au

Brisbane

31A Cordova St
Milton
Qld 4064
Telephone: (07) 3368 3878
Fax: (07) 3368 3863
sales.qld@pertronic.com.au